

BEA Optimized Control Topology for Enhancement in a Grid Converter for WPS Application

Ch. Sri Mrudula¹, Dr. K. Sreelatha²

PG Scholar, Department of EEE, St. Peter's Engineering College, Hyderabad, India¹.

Professor & Head, Department of EEE, St. Peter's Engineering College, Hyderabad, India²

Abstract—India, over the years, has been a trend-setting nation with regard to Wind Power Utilization and decades of concentrated efforts have started to yield gratifying results. Penetrating the wind energy into the grid affects the power quality due to variable wind speed components. The foremost power quality snags are active power, reactive power, voltage sag, voltage swell, flicker, and harmonics. This paper shows the existence of power quality problem due to installation of wind turbine with the grid. A new BEA Tuned PI based STATCOM scheme for grid connected wind power system has been developed using the MATLAB/SIMULINK to mitigate the power quality problems. Finally the results of with BEA Tuned PI based STATCOM and without BEA Tuned PI based STATCOM are compared and a mark reduction in total harmonic reduction is observed.

Keywords— BEA; PQ power quality; STATCOM; WPS Wind power system;

I. INTRODUCTION

Now India increasingly choosing to replace fossil fuels with renewable energy sources. Among the factors driving people to preemptively seek out different sources of energy are fears about a reliance on fossil-fuel imports, resource depletion, and anthropogenic climate change. Developing renewable energy requires the creation of specific technologies. The Indian Wind Energy program has been very successful in commercializing wind energy and India stands 5th in the World in terms of installed wind power capacity of 19832 MW as on

June 2013, contributes to around 75% of the grid-connected renewable energy power in the country. The wind energy market is continuing to grow steadily in India along with the rest of the world. India is now one of the global manufacturing hubs for wind turbines with about 23 large wind turbine manufacturers, capacity ranging from 225 kW to 2500 kW and several small wind turbine manufacturers producing capacity ranging from 300 W to 50 kW

The need to integrate the renewable energy like wind energy into power system is to make it possible to minimize the environmental impact on conventional plant [1]. The integration of wind energy into existing power system presents a technical challenges and that requires consideration of voltage regulation, stability, power quality problems. The power quality is an essential customer-focused measure and is greatly affected by the operation of a distribution and transmission network. The issue of power quality is of great importance to the wind turbine [2]. There has been an extensive growth and quick development in the exploitation of wind energy in recent years. The individual units can be of large capacity up to 2 MW, feeding into distribution network, particularly with customers connected in close proximity [3].

Today, more than 28000 wind generating turbine are successfully operating all over the world. In the fixed-speed wind turbine operation, all the fluctuation in the wind speed are transmitted as fluctuations in the mechanical torque, electrical power on the grid and leads to large voltage fluctuations. During the normal operation, wind turbine

produces a continuous variable output power. These power variations are mainly caused by the effect of turbulence, wind shear, and tower-shadow and of control system in the power system. Thus, the network needs to manage for such fluctuations. The power quality issues can be viewed with respect to the wind generation, transmission and distribution network, such as voltage sag, swells, flickers, harmonics etc. However the wind generator introduces disturbances into the distribution network. One of the simple methods of running a wind generating system is to use the induction generator connected directly to the grid system. The induction generator has inherent advantages of cost effectiveness and robustness. However; induction generators require reactive power for magnetization. When the generated active power of an induction generator is varied due to wind, absorbed reactive power and terminal voltage of an induction generator can be significantly.

II. BATS ECHOLOCATION ALGORITHM

The Bat algorithm is a metaheuristic algorithm for global optimization. It was inspired by the echolocation behaviour of microbats, with varying pulse rates of emission and loudness.[1][2] The Bat algorithm was developed by Xin-She Yang in 2010.

The idealization of the echolocation of microbats can be summarized as follows: Each virtual bat flies randomly with a velocity v_i at position (solution) x_i with a varying frequency or wavelength and loudness A_i . As it searches and finds its prey, it changes frequency, loudness and pulse emission rate r . Search is intensified by a local random walk. Selection of the best continues until certain stop criteria are met. This essentially uses a frequency-tuning technique to control the dynamic behaviour of a swarm of bats, and the balance between exploration and

exploitation can be controlled by tuning algorithm-dependent parameters in bat algorithm.

A detailed introduction of metaheuristic algorithms including the bat algorithm is given by Yang[4] where a demo program in Matlab/Octave is available, while a comprehensive review is carried out by Parpinelli and Lopes.[5] A further improvement is the development of an evolving bat algorithm (EBA) with better efficiency.[6]

III. TOPOLOGY FOR POWER QUALITY IMPROVEMENT

The STATCOM based current control voltage source inverter injects the current into the grid in such a way that the source current are harmonic free and their phase-angle with respect to source voltage has a desired value. The injected current will cancel out the reactive part and harmonic part of the load and induction generator current, thus it improves the power factor and the power quality. To accomplish these goals, the grid voltages are sensed and are synchronized in generating the current command for the inverter. The proposed grid connected system is implemented for power quality improvement at point of common coupling (PCC), as shown in Fig. 1.[5]

The grid connected system in Fig. 1, consists of wind power generation system and battery energy storage system with STATCOM.

A. Wind Power system

In this configuration, wind generations are based on constant speed topologies with pitch control turbine. The induction generator is used in the proposed scheme because of its simplicity, it does not require a separate field circuit, it can accept constant and variable loads, and has natural protection against short circuit. The available power of wind energy system is presented as under in (1).

$$P_{wind} = \frac{1}{2} \rho A V_{wind}^3 \tag{1}$$

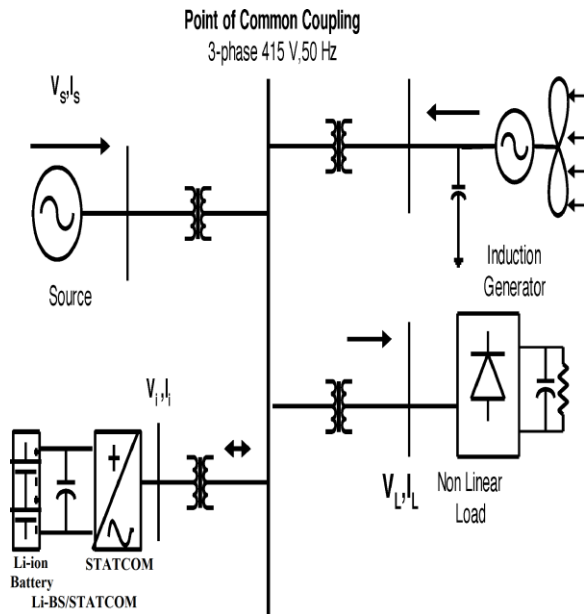

Fig. 1. Grid connected system for power quality improvement.

Where $\rho(\text{kg/m}^3)$ is the air density and $A (\text{m}^2)$ is the area swept out by the turbine blade, V_{wind} is the wind speed in mtr/s. It is not possible to extract all kinetic energy of wind, thus it extract a fraction of power in wind, called power coefficient C_p of the wind turbine, and is given in (2).

$$P_{mech} = C_p P_{wind} \tag{2}$$

where C_p is the power coefficient, depends on type and operating condition of wind turbine. This coefficient can be express as a function of tip speed ratio λ and pitch angle θ . The mechanical power produce by wind turbine is given in (3)

$$P_{mech} = \frac{1}{2} \rho \pi R^2 V_{wind}^3 C_p \tag{3}$$

Where R is the radius of the blade (m).

B. BESS STATCOM

The Battery energy storage system is used as an energy storage element for the purpose of voltage regulation. This will naturally maintain dc capacitor voltage

constant and is best suited in STATCOM since it rapidly injects or absorbed reactive power to stabilize the grid system. It also controls the distribution and transmission system in a very fast rate. When power fluctuation occurs in the system, this can be used to level the power fluctuation by charging and discharging operation. The battery is connected in parallel to the dc capacitor of STATCOM [6]–[10].

The STATCOM is a three-phase voltage source inverter having the capacitance on its DC link and connected at the point of common coupling. The STATCOM injects a compensating current of variable magnitude and frequency component at the bus of common coupling.

C. System Operation

The shunt connected STATCOM with battery energy storage is connected with the interface of the induction generator and non-linear load at the PCC in the grid system. The STATCOM compensator output is varied according to the controlled.

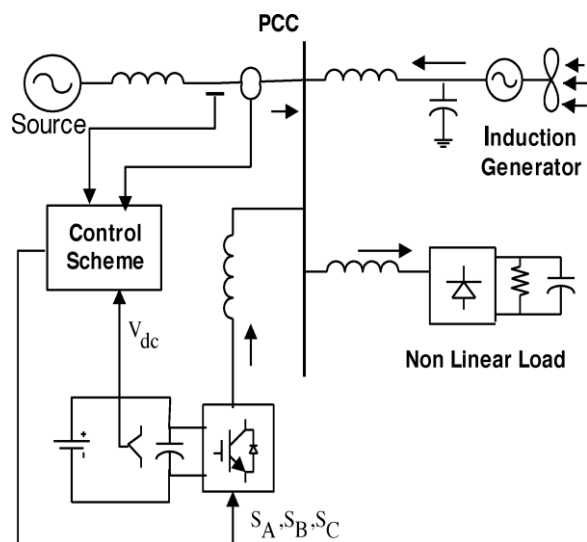

Fig: 3 System operational scheme in grid system.

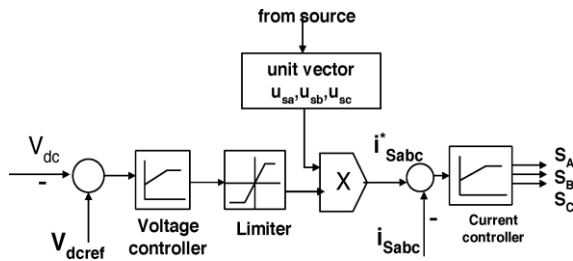

Fig: 4 Control system scheme

strategy, so as to maintain the power quality norms in the grid system. The current control strategy is included in the control scheme that defines the functional operation of the STATCOM compensator in the power system. A single STATCOM using insulated gate bipolar transistor is proposed to have a reactive power support, to the induction generator and to the nonlinear load in the grid system. The main block diagram of the system operational scheme is shown in Fig: 3

IV. CONTROL SCHEME

The control scheme approach is based on injecting the currents into the grid using “bang-bang controller.” The controller uses a hysteresis current controlled technique. Using such technique, the controller keeps the control system variable between boundaries of hysteresis area and gives correct switching signals for STATCOM operation.

The control system scheme for generating the switching signals to the STATCOM is shown in Fig: 4

The control algorithm needs the measurements of several variables such as three-phase source current i_{Sabc} , DC voltage V_{dc} , inverter current i_{iabc} with the help of sensor. The current control block, receives an input of reference current i_{Sabc}^* and actual current i_{Sabc} are subtracted so as to activate the operation of STATCOM in current control mode [11]–[13].

A. Grid Synchronization

In three-phase balance system, the RMS voltage source amplitude is calculated at the sampling frequency from the source phase voltage (V_{sa} , V_{sb} , V_{sc}) and is expressed, as sample template V_{sm} , sampled peak voltage, as in (6).

$$V_{sm} = \left\{ \frac{2}{3} (V_{sa}^2 + V_{sb}^2 + V_{sc}^2) \right\}^{\frac{1}{2}}$$

(6) The in-phase unit vectors are obtained from AC source—phase

Voltage and the RMS value of unit vectors are shown in (7).

$$u_{sa} = \frac{V_{sa}}{V_{sm}}, \quad u_{sb} = \frac{V_{sb}}{V_{sm}}, \quad u_{sc} = \frac{V_{sc}}{V_{sm}}$$

(7)

The in-phase generated reference currents are derived using in-phase unit voltage template as, in (8).

$$I_{sa}^* = I \cdot u_{sa}, \quad I_{sb}^* = I \cdot u_{sb}, \quad I_{sc}^* = I \cdot u_{sc}$$

(8)

Where I is proportional to magnitude of filtered source voltage for respective phases. This ensures that the source current is controlled to be sinusoidal. The unit vectors implement the important function in the grid connection for the synchronization for STATCOM. This method is simple, robust and favorable as compared with other methods [13].

B. Histerisis Controller

Hysteresis current controller is implemented in the current control scheme. The reference current is generated as in (7) and actual current are detected by current sensors and are subtracted for obtaining a current error for a hysteresis based bang-bang controller. Thus the ON/OFF switching signals for IGBT of STATCOM are derived from hysteresis controller [14].

The switching function S_A for phase ‘a’ is expressed as (9).

$$\begin{aligned} i_{sa} < (I_{sa}^* - HB) &\rightarrow S_A = 0 \\ i_{sa} > (I_{sa}^* + HB) &\rightarrow S_A = 1 \end{aligned} \quad (9)$$

where HB is a hysteresis current-band, similarly the switching function S_B, S_C can be derived for phases “b” and “c”.

V. SYSTEM PERFORMANCE

The proposed control scheme is simulated using SIMULINK in power system block set. The system parameter for given system is given Table I.

The system performance of proposed

system under dynamic Condition is also presented.

A. Voltage Source Inverter

The three phase injected current into the grid from STATCOM will cancel out the distortion caused by the non- linear load and wind generator. The IGBT based three-phase inverter is connected to grid through the transformer. The generation of switching signals from reference current is simulated within hysteresis band of 0.08. The choice of narrow hysteresis band switching in the system improves the current quality.

The choice of the current band depends on the operating voltage and the interfacing transformer impedance. The compensated current for the nonlinear load and demanded reactive power is provided by the inverter. The real power transfer from the batteries is also supported by the controller of this inverter. The three phase inverter injected current are shown in Fig: 5

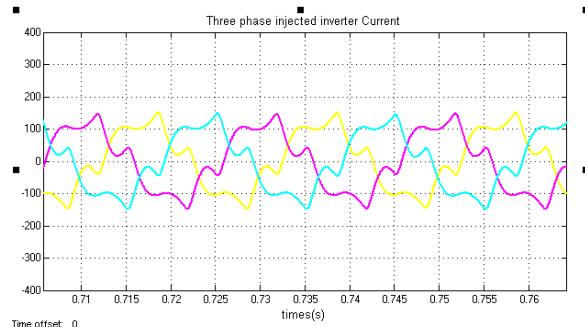

Fig: 5 Three phase injected inverter Current.

B. STATCOM – Performance under load variation

The wind energy generating system is connected with grid having the nonlinear load. The performance of the system is measured by switching the STATCOM at time = 0.7s in the system and how the STATCOM responds to the step change command for increase in additional load at 1.0 s is shown in the simulation. When STATCOM controller is made ON, without change in any other load condition parameters, it starts to mitigate for reactive demand as well as harmonic current. The dynamic performance is also carried out by step change in a load, when applied at 1.0 s. This additional demand is fulfill by STATCOM compensator. Thus, STATCOM can regulate the available real power from source. The results of source current, load current are shown in Fig: 6(a) and (b) respectively. While the results of injected current from STATCOM are shown in Fig. 6(c) and the generated current from wind generator at PCC are depicted in Fig. 5(d).

The DC link voltage regulates the source current in the grid system, so the DC link voltage is maintained constant across the capacitor as shown in Fig: 7 (a). The current through the dc link capacitor indicating the charging and discharging operation as shown in Fig: 7 (b).

TABLE I
SYSTEM PARAMETERS

S.NO	Parameters	Rating
1	Grid Voltage	3-phase, 415V, 50Hz
2	Induction Motor/Generator	3.35KVA, 415V, 50Hz, P=4, Speed = 1440 rpm, Rs = 0.01Ω, Rr = 0.015Ω, Ls = 0.06H, Lr = 0.06H
3	Line Series Inductance	0.05mh
4	Inverter Parameters	DC Link Voltage = 800V, DV Link Capacitance = 100μF, Switching frequency = 2kHz
5	IGBT Rating	Collector Voltage = 12000V, Forward current = 50A, Gate Voltage =20V, Power dissipation = 310W
6	Load parameter	Non-linear Load = 25kW.

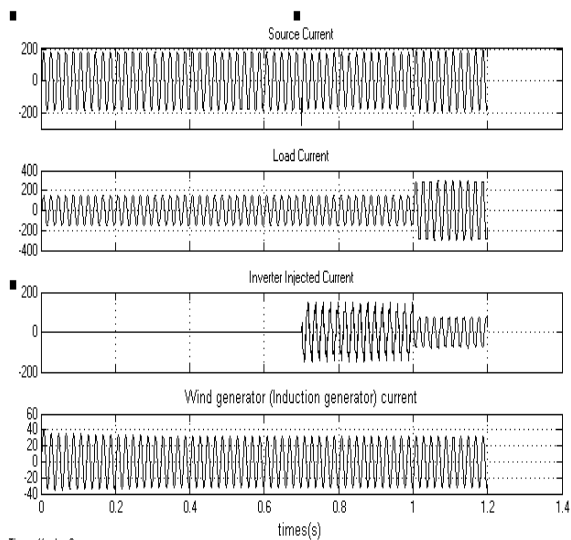

Fig: 6 (a) Source Current. (b) Load Current. (c) Inverter Injected Current. (d) Wind generator (Induction generator) current

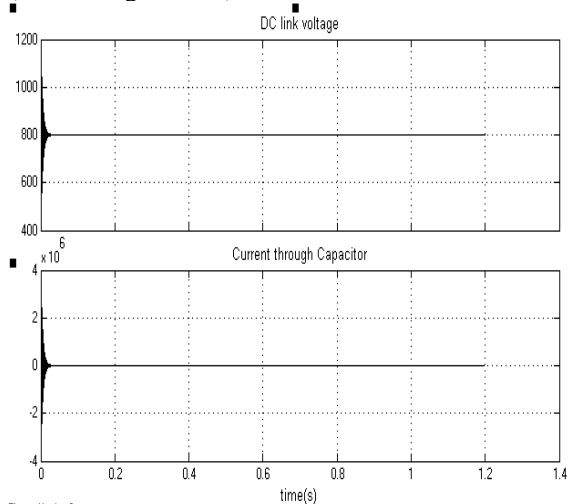

Fig: 7 (a) DC link voltage. (b) Current through Capacitor.

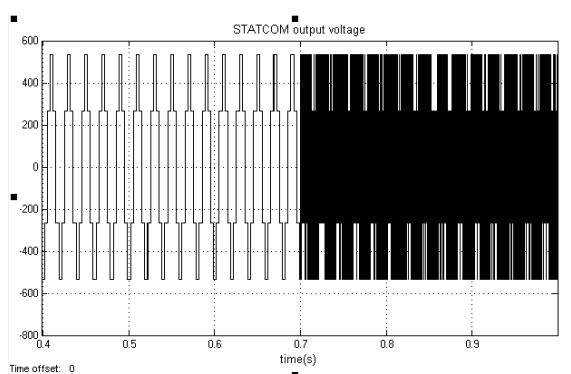

Fig: 8 STATCOM output voltage

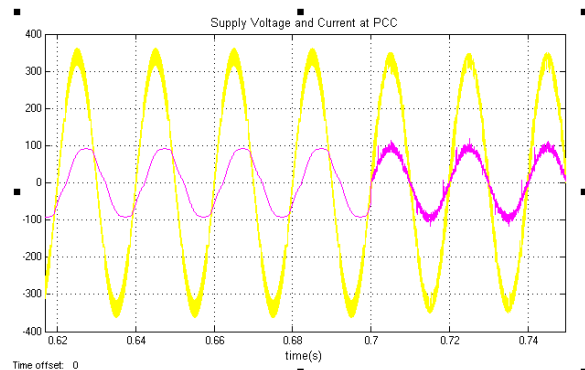

Fig: 9 Supply Voltage and Current at PCC

C. Power quality improvement by BEA/STATCOM:

It is observed that the source current on the grid is affected due to the effects of nonlinear load and wind generator, thus purity of waveform may be lost on both sides in the system. The inverter output voltage under STATCOM operation with load variation is shown in Fig: 8. The power factor is improve can be seen in Fig: 9. The dynamic load does affect the inverter output voltage. From FFT analysis, it is observed that in Fig: 10 the Total Harmonic Distortion (THD) of the source current waveform of the test system without BEA STATCOM is 5.34%.

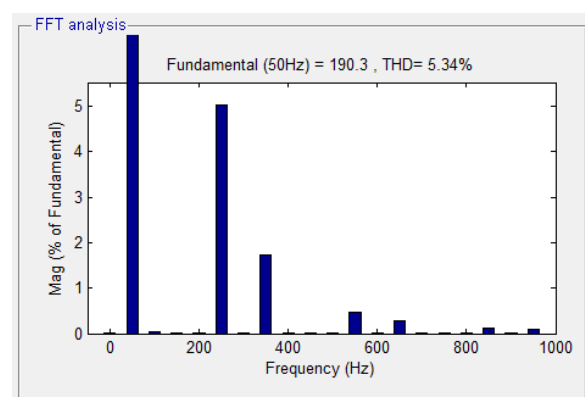

Fig:10 THD of source current without BEA STATCOM

Form Fig: 11 the THD of source current of test system with BEA STATCOM is 0.25%.

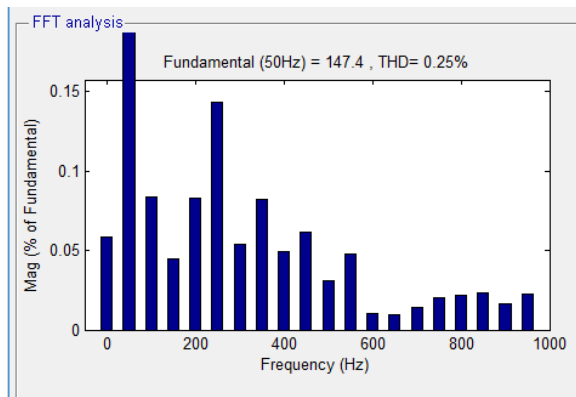

Fig: 11 THD of source current with Li-BS STATCOM.

Hence from the FFT analysis it is observed that the mark reduction in THD for BEA STATCOM.

VI. CONCLUSION

In this paper BEA Tuned PI Scheme based STATCOM is presented for grid connected Wind power Generating System. The proposed BEA STATCOM have improved the power quality of source current significantly by reducing the THD from 5.34% to 0.25%. It is clearly presented that STATCOM with BEA control scheme gives better performance.

REFERENCES

- [1] A. Sannino, "Global power systems for sustainable development," in *IEEE General Meeting, Denver, CO, Jun. 2004*.
- [2] K. S. Hook, Y. Liu, and S. Atcity, "Mitigation of the wind generation integration related power quality issues by energy storage," *EPQU J.*, vol. XII, no. 2, 2006.
- [3] R. Billinton and Y. Gao, "Energy conversion system models for adequacy assessment of generating systems incorporating wind energy," *IEEE Trans. on E. Conv.*, vol. 23, no. 1, pp. 163–169, 2008, Multistate.
- [4] Karen L. Butler, Mehrdad Ehsani, Preyas Kamath, "Matlab-Based Modeling and Simulation Package for Electric and Hybrid Electric Vehicle Design", published in *IEEE transactions on vehicular technology*, vol. 48, no. 6, pp. 1770-1778, November 1999.
- [5] S. W. Mohod and M. V. Aware, "A STATCOM-Control Scheme for Grid Connected Wind Energy System for Power Quality Improvement", *Published in. Systems Journal, IEEE (Volume:4 , Issue: 3)*, pp. 346-352, sept 2010.
- [6] Chen, Min, and G. A. Rincon-Mora. 2006. *Accurate electrical battery model capable of predicting runtime and I-V performance. IEEE Transactions on Energy Conversion 21 (2):504-511.*
- [7] Schweighofer, B., K. M. Raab, and G. Brasseur. 2003. *Modeling of high power automotive batteries by the use of an automated test system. IEEE Transactions on Instrumentation and Measurement 52 (4):1087-1091.*
- [8] Tremblay, O, Dessaint, L.-A. "Experimental Validation of a Battery Dynamic Model for EV Applications." *World Electric Vehicle Journal. Vol. 3 - ISSN 2032-6653 - © 2009 AVERE, EVS24 Stavanger, Norway, May 13 - 16, 2009.*
- [9] T. Kinjo and T. Senjyu, "Output leveling of renewable energy by electric double layer capacitor applied for energy storage system," *IEEE Trans. Energy Conv.*, vol. 21, no. 1, Mar. 2006.
- [10] R. S. Bhatia, S. P. Jain, D. K. Jain, and B. Singh, "Battery energy storage system for power conditioning of renewable energy sources," in *Proc. Int. Conf. Power Electron Drives System, Jan. 2006*, vol. 1, pp.501–506.
- [11] Fu. S. Pai and S.-I. Hung, "Design and operation of power converter for microturbine powered distributed generator with capacity expansion capability," *IEEE Trans. Energy Conv.*, vol. 3, no. 1, pp. 110–116, Mar.2008.
- [12] J. Zeng, C. Yu, Q. Qi, and Z. Yan, "A novel hysteresis current control for active power filter with constant frequency," *Elect. Power Syst. Res.*, vol. 68, pp. 75–82, 2004.
- [13] M. I. Milands, E. R. Cadavai, and F. B. Gonzalez, "Comparison of control strategies for shunt active power filters in three phase four wire system," *IEEE Trans. Power Electron.*, vol. 22, no. 1, pp. 229–236, Jan.2007.
- [14] S. W. Mohod and M. V. Aware, "Power quality issues & it's mitigation technique in wind energy conversion," in *Proc. of IEEE Int. Conf. Quality Power & Harmonic, Wollongong, Australia, 2008.*

Authors



Ch. Sri Mrudula - Obtained B.Tech degree in Electrical and Electronics Engineering from Padma Shri Dr. B V. Raju Institute of Technology, Narsapur, Medak District, Telangana, India in 2018. At present, she is pursuing M.Tech degree in Electrical Power Systems from St. Peter's Engineering College, Maisammaguda, Hyderabad, Telangana, India.



Dr. K. Sreelatha - Obtained PhD in Power Systems from JNTU Anantapur, India in 2018. At present, she is the Head of the Department of Electrical and Electronics Engineering at St. Peter's Engineering College, Maisammaguda, Hyderabad, India. Her research interests include Renewable Energy Systems and Power Quality. She has 7 publications in international and 2 publications in national journals. She has 2 publications in international and 3 publications in national conferences.